

LKSTL50-PS LKSTL120-PS

IP66 STREET LIGHT. POWER SELECTABLE



NEMA socket and isolating cap

Application:

- Roads
- Parking areas
- Paths

Construction:

- Die cast aluminium body
- Tempered glass
- Grey, powder coated finish
- With NEMA socket and isolating cap

Specifications:

- Input Voltage: 100-277 VAC 50/60Hz
- LEDs; Philips Lumileds
- Driver: Inventronics
- Beam Angle: 100°
- CCT: 4000K
- CRI > 70
- IP Rating: IP66
- Operating Temp.: -40°C to + 131°C
- IK Rating: 08
- Surge Protection: 20KV
- Spigot size: 76mm
- Warranty: 5 years

- Power selectable 20W / 30W / 50W
20W - 2650Lm. 133Lm/W (4000K)
30W - 3900Lm. 130Lm/W (4000K)
50W - 7300Lm. 142Lm/W (4000K)

- Power selectable 80W / 100W / 120W
80W - 11000Lm. 136Lm/W (4000K)
100W - 14282Lm. 140Lm/W (4000K)
120W - 16560Lm. 137Lm/W (4000K)

Options:

- Photocell available

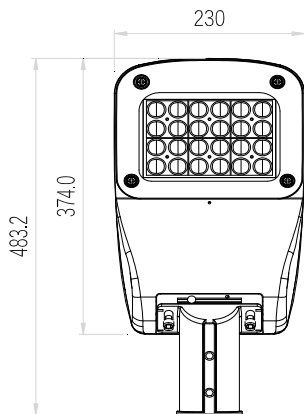
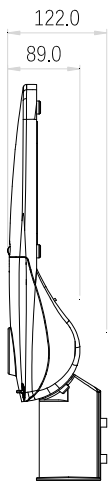

50W

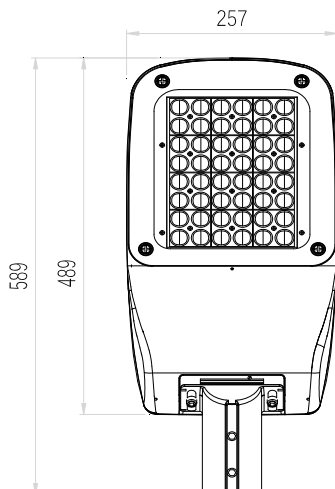

120W